

OWNER' S MANUAL

- Suitable for 3+ Years
- Maximum user weight: 30 kg

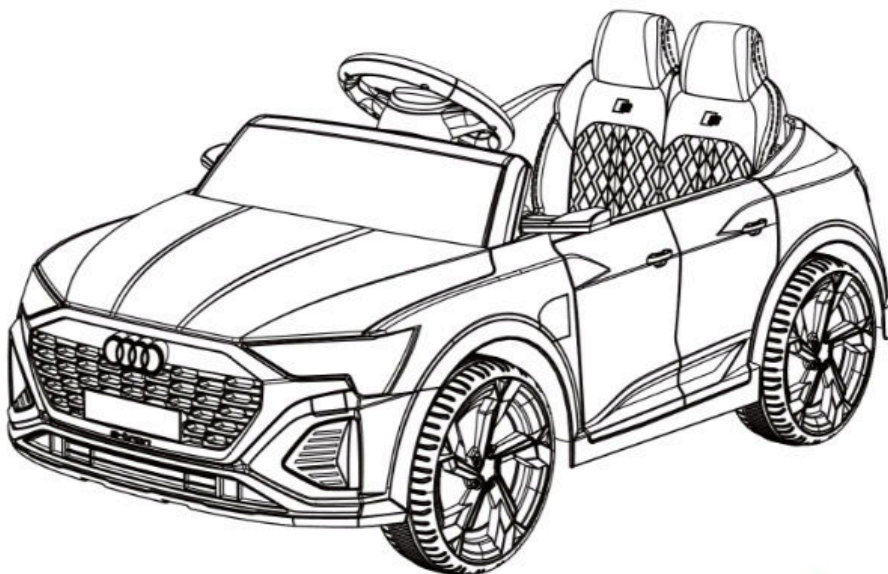

WARNING Must be assembled by an adult.

OWNERS MANUAL

with Assembly Instructions

Read and understand this entire manual before using!

Please keep this manual for future reference as it contains important information. Before first time use, charge the battery for at least 4-6 hours, but no more than 10 hours.

On the purchase of your new Ride-On.

This ride-on car will provide your child with many miles of riding of enjoyment. To help assure you and your rider a safe ride we ask you to please read this manual carefully, and keep it for future reference.

Follow the recommendations in this manual, they are designed to improve the safety and operation of your ride-on car and its rider.

Toys intended to be assembled by an adult shall:

- have packaging and instructions that prominently indicate that the article is to be assembled by an adult ;
- have assembly instructions that highlight any connections that are important for the safe use of the toy, for example connections that prevent failures that may be, or cause, hazards;
- have instructions that include information on the potential hazards resulting from incorrect assembly if this could reasonably result in the creation of a hazard.

Specification

Battery	12V4.5AH X1
Charger	12V500mA
input	Depend on local voltage
Motor	390-18000

Suitable age:	3+ Years
Charge time:	4-6 hours
Load capacity:	Under 30 kg
Speed:	3-5KM/H



BATTERY INFORMATION

- Non-rechargeable batteries are not to be recharged. battery is not replaceable.
- If removable rechargeable batteries are used, they are only to be charged under adult supervision.
- Remove rechargeable batteries from the product before charging.
- Do not mix old and new batteries. Do not mix different types of batteries: alkaline, standard (carbon-zinc) or rechargeable (nickel-cadmium).
- Insert batteries as indicated inside the battery compartment, anode to anode, cathode to cathode.
- Remove batteries during long periods of non-use. Always remove exhausted batteries from the product. Battery leakage and corrosion can damage this product. Dispose of batteries safely.
- Never short circuit the battery terminals.

Parts List

B**①**

vehicle body

x1**②**

mirrors

x1**③**

wind shield

x1**④**steering wheel **x1****⑤**

seat

x1**⑥**

Ø4*14 screw

x1**⑦**

motor

x2**⑧**

gasket

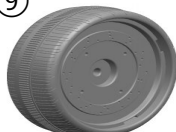
x6**⑨**

wheel

x4**⑩**

nut

x4**⑪**

wheel cover

x4

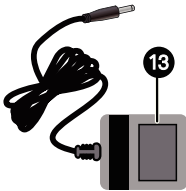
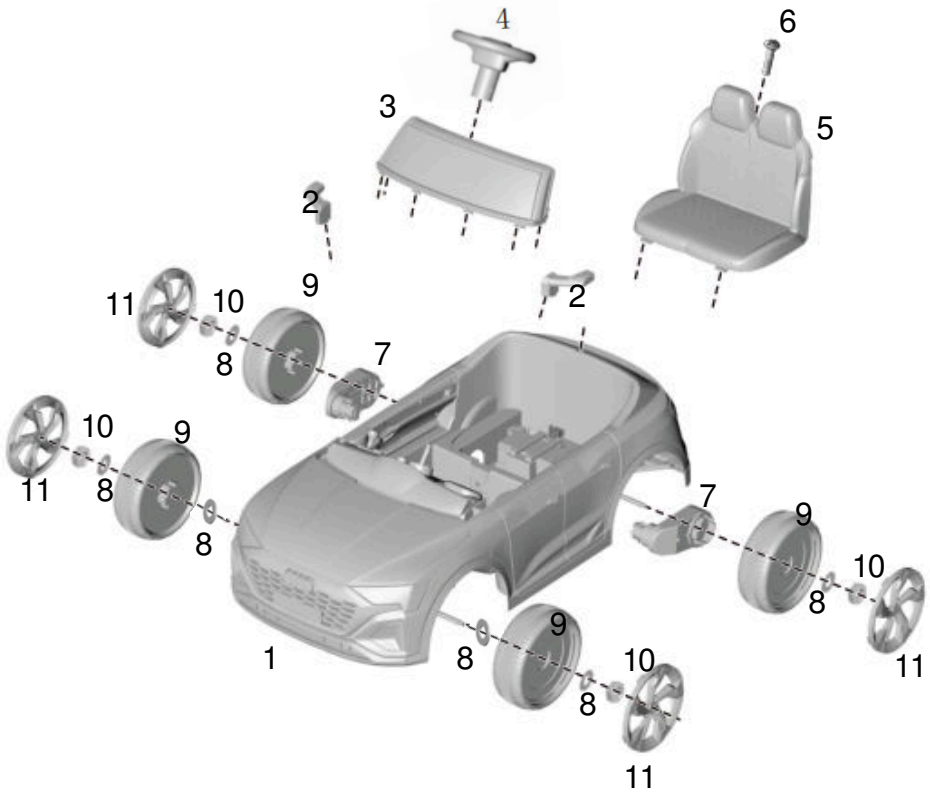

Assembly tools required:



Screwdriver
(not included)



PREVENT INJURIES AND DEATHS:

- **NEVER LEAVE CHILD UNATTENDED. ADULT DIRECT SUPERVISION IS REQUIRED.** Always keep child in view when child is in vehicle.
- This toy should be used with caution since skill is required to avoid falls or collisions causing injury to the user or third parties.
- Protective equipment should be worn.
- Never use in roadways, near cars, or on near steep inclines or steps, swimming pools or other bodies of water.
- Always wear shoes, always sit on the seat.
- Not to be used in traffic.
- This toy is unsuitable for children under 36 months due to its maximum speed; Maximum user weight is 30 kg.
- This toy has no brake.



WARNING:

- **CHOKING HAZARD!** Not suitable for children under 36 months.
- **Must be assembled by an adult.**

Rules for Safe Riding

- Keep Children within Safe Riding Areas:
 - Never use in roadway, near motor vehicles, on lawn space, on or near steep inclines or steps, swimming pools or other bodies of water;
- Use the toy only on flat surfaces. Such as inside your house, garden or playground.
- Never use in the dark. A child could encounter unexpected obstacles and have an accident. Operate the vehicle only in the daytime or a well-lit area.
- It is prohibited to change the circuit or add other electric parts
- Inspect wires and connections of the vehicle periodically.
- Do not let any child touch the wheels or be near them when the car is moving .
- This vehicle has adjustable play seat belts. Please instruct children how to tie the safety belt before using, guarantee the security.

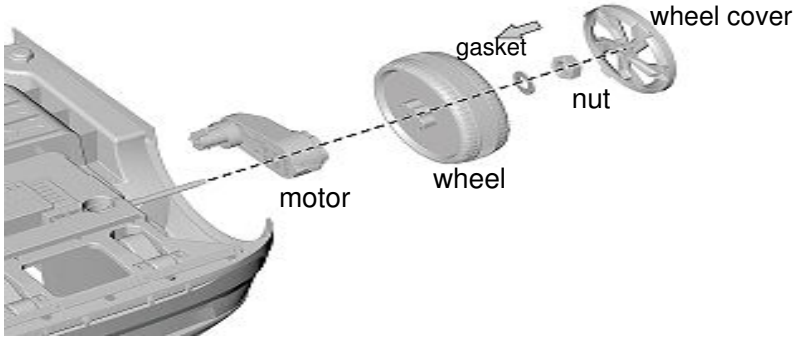
E**Attach the wheel**

1. Turn the bottom of the toy car up as above picture show.
2. Push the wheel to the back axle and make the wheel connect well with the motor.
3. Put a gasket to the other side of the wheel.
4. Tighten the wheel with a M8 nut.
5. Insert the Wheels cover.
6. The other wheel to be installed as the same way.

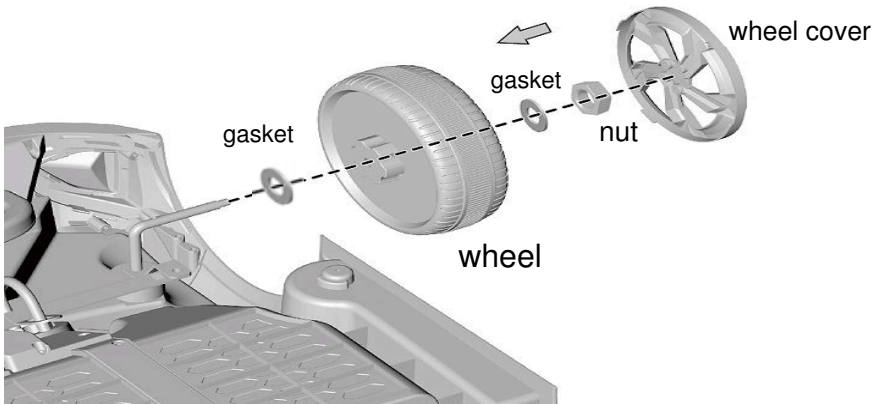

1. Turn the bottom of the toy car up as above picture show.
2. Slide the gasket into the front axle.
3. Push the wheel to the front axle.
4. Put a gasket to the other side of the wheel.
5. Tighten the wheel with a M8 nut.
6. Insert the Wheels cover.
7. The other wheel to be installed as the same way.

Attach the Steering wheel & Mirror

E

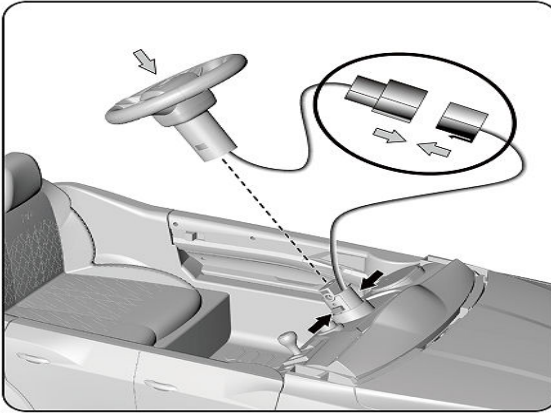

1. Connect the steering wheel to the wires in the instrument panel. If the wires are too long, they can be retracted into the instrument panel.

2. Press two protruding black buttons firmly, and insert the corresponding card slot of the steering wheel, when hearing a "click" sound, that is, the installation is complete.

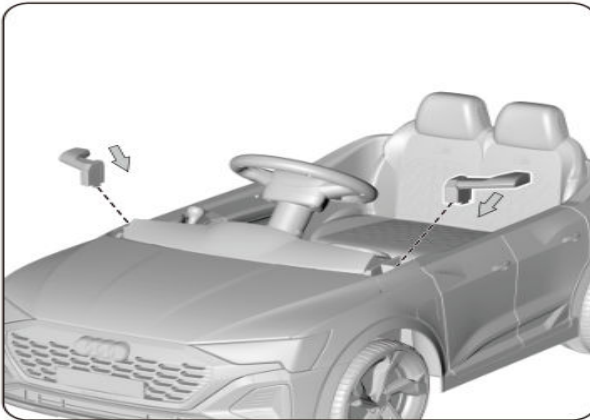

Make the slots in the mirror in the same line with the slots in car body and press the mirrors into the gaps.

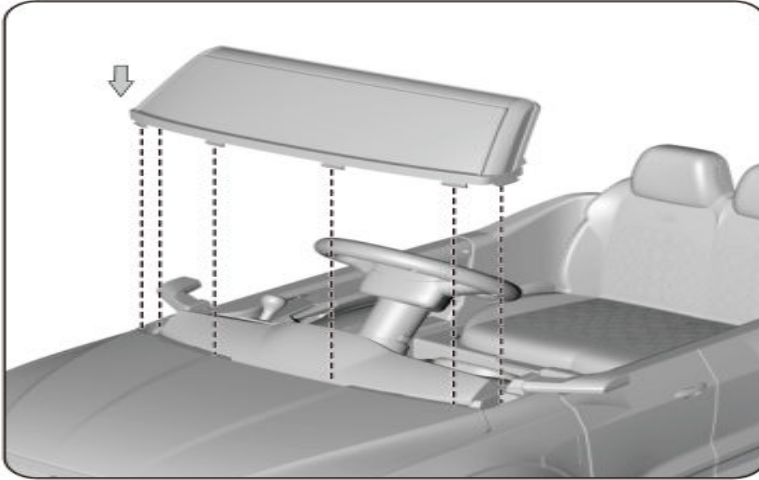
E**Attach the Windshield and Seat**

Check the slot and press the windshield according to the slot location to the gap end.

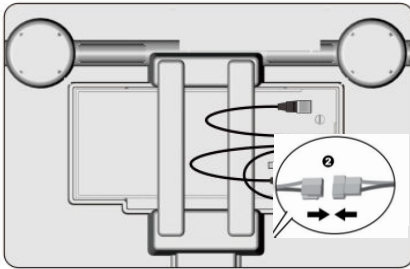

Plug the red connector on the vehicle body into the red connector from the battery.

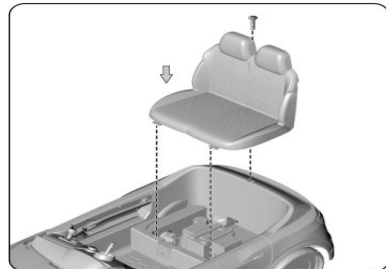

Put the seat onto the car body according to above picture, and tight the seat well using $\text{Ø}4*14$ self tapping screw.

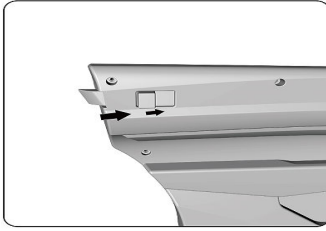

When your child is going out of the car, please open the door buttons like above pictures show. And when the child is driving, please do not forget to lock the doors with above buttons.

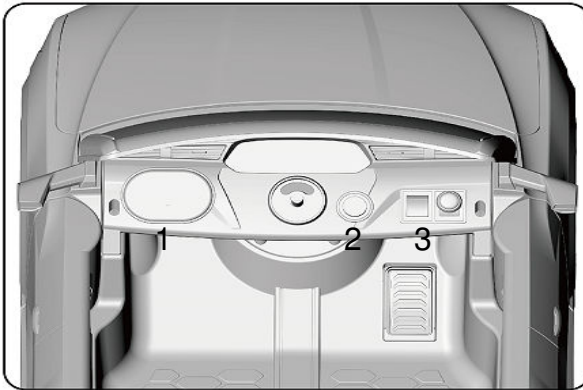

1. Player

2. Power button: To turn on or off the power.

3. Forward/backward switch: Operate it together with the accelerator to make the vehicle to go forward/backward.



2.4G Remote Control Instructions

Step1:The Remote Controller is loaded with two AAA batteries (battery prepared by yourself).

Step2:Turn off the power switch on the vehicle.

Step3:Hold down "▲" "&"▼ " keys for 3 seconds start match code, the first LED flicker.Now turn on the vehicle power switch.The red indicator lights stop flashing,and the code is successful.

1. Keys caption:"S" set up speed,1 led lit up is low speed,2 leds lit up is medium speed, 3 leds lit up is high speed.

2. "▲" " Forward,"▼" " Back,"◀" " Left, "▶" Right,Press "P"key hold the brake,ALL LED flicker

3. Remote control button automatically open,without tou ching about 2 minutes,it will shut down automatically.



A. With a screwdriver remove both screws from the protective cover (under the seat).

B. Remove the protective cover. (Keep protective cover and screws for future use.)

R/C-PEDAL Switch: Press the switch into the " R/C" position, the turning and movement of the product will be controlled by the remote controller. Press the switch into the " PEDAL" position to turn off the remote control function. Product steering will be controlled by the steering wheel and movement by the foot pedal.

NOTE:

- Leave the remote controller idling for about 10 seconds, it will shut down automatically.
- Rebuild connection when you replace the batteries of the remote controller.



WARNING!

ONLY AN ADULT CAN CHARGE AND RECHARGE THE BATTERY!



WARNING!

This product with **Charging Protection**: when charging, all functions will be cut off! Only an adult can charge and recharge the battery!

- The POWER SWITCH must be turned in **OFF** position when charging.
- Before the first use, you should charge the battery for 4-6 hours. Do not recharge the battery for more than 10 hours to avoid overheating the charger.
- When the vehicle begins to run slowly, recharge the battery.
- After each use or once a month minimum recharge time as 8 to 12 hours, less than 20 hours at most.
- Use the only rechargeable battery and charger supplied with your vehicle. **NEVER** substitute the battery or the charger with another brand. Using another battery or charger may cause a fire or explosion.
- Do not use the battery or charger for any other product.

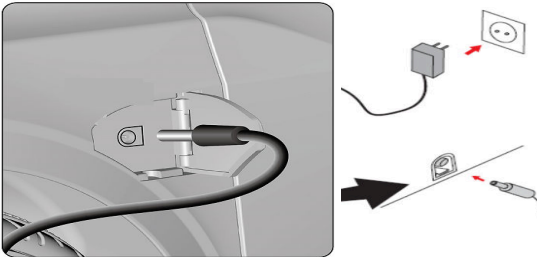

1. Plug the charger port into the input socket. (below the seat)
2. Plug the charger plug into a wall outlet. The battery will begin charging.



WARNING :

To reduce the risk of injury, adult supervision is required. Never use in roadways, near motor vehicles, on or near steep inclines or steps, swimming pools or other bodies of water, always wear shoes, and never allow more than one rider.

WARNING :RISK OF FIRE. Do not bypass. Replace only with 7A.

CHOKING HAZARD—Small parts. Not for children under 3 yrs.

Problem	Possible Cause	Solution
Vehicle does not run	Battery low on power	Recharge battery.
	Thermal fuse has tripped	Reset fuse, see <Fuse>
	Battery connector or wires are loose	Check that the battery connectors are firmly plugged into each other. If wires are loose around the motor contact your distributor please.
	Battery is dead	Replace battery, contact your distributor please.
	Electrical system is damaged	Contact your distributor please.
	Motor is damaged	Contact your distributor please.
Vehicle does not run very long	Battery is under charged	Check that the battery connectors are firmly plugged into each other when recharging
	Battery is old	Replace battery, contact your distributor please.
Vehicle runs sluggishly	Battery low on power	Recharge battery, contact your distributor please.
	Battery is old	Replace battery, contact your distributor please.
	Vehicle is overload	Reduce weight on vehicle.
	Vehicle is being used in harsh conditions	Avoid using vehicle in harsh conditions ,see <Safety>.
Vehicle needs a push to go forward	Poor contact of wires or Connectors	Check that the battery connectors are firmly plugged into each other. If wires are loose around the motor, contact your distributor please.
	“Dead Spot” on motor	A dead spot means the electric power is not being delivered to the terminal connection and the vehicle needs repair. Contact your distributor please.
Difficult shifting from forward to reverse or vice-versa	Attempting to shift while the vehicle is motion	Completely stop the vehicle and shift, see <Use Your New Vehicle>
Loud grinding or clicking noises coming from motor or gear box	Motor or gears are damaged	Contact your distributor please.
Battery will not recharge	Battery connector or adapter connector is loose	Check that the battery connectors are firmly plugged into each other.
	Charger not plugged in	Check that the battery charger is plugged into a working wall outlet.
	Charger is not working	Contact your distributor please.
Charger feels warm when recharging	This is normal and not a cause for concern	

Completely read through this manual and the troubleshooting guide table before calling. If you still need help resolving the problem **Contact your distributor please.**

- It is parents' responsibility to check main parts of the toy before using, must regularly examine for potential hazard, such as the battery, charge, cable or cord, plug, screws are fastening enclosure of other parts and that in the event of such damage, the toy must not be used until that damage had been properly removed.
- Make sure the plastic parts of the vehicle are not cracked or broken.
- Occasionally use a lightweight oil to lubricate moving parts such as wheels.
- Park the vehicle indoors or cover it with a tarp to protect it from wet weather.
- Keep the vehicle away from sources of heat, such as stoves and heaters. Plastic parts may melt.
- Recharge the battery after each use. Only an adult can handle the battery. Recharge the battery at least once a month when the vehicle Raider is not being used.
- Do not wash the vehicle with a hose. Do not wash the vehicle with soap and water. Do not drive the vehicle in rainy or snowy weather. Water will damage the motor, electric system and battery.
- Clean the vehicle with a soft, dry cloth. To restore shine to plastic parts, use a non-wax furniture polish. Do not use car wax. Do not use abrasive cleaners.
- Do not drive the vehicle in loose dirt, sand or fine gravel which could damage the moving parts, motors or the electric system.
- When not using, all the electrical source should be turn off. Turn off the power switch and disconnect the battery connection.

The battery features a thermal fuse with a reset fuse that will automatically trip and cut all power to the vehicle if the motor, electric system or battery is overloaded. The fuse will reset and power will be restored after the unit is turned OFF for 20 seconds and then turned ON again. If the thermal fuse trips repeatedly during normal use, the vehicle may need repair. **Contact your distributor please.**

To avoid losing power, follow these guidelines:

- Do not overload the vehicle.
- Do not tow anything behind the vehicle.
- Do not drive up steep slopes.
- Do not drive into fixed objects, which may cause the wheels to spin, causing the motor to overheat.
- Do not drive in very hot weather, components may overheat.
- Do not allow water or other liquids to come in contact with the battery or other electric components.
- Do not tamper with the electric system. Doing so may create a short, causing the fuse to trip.

Disposal Of Battery



- Your sealed lead-acid battery must be recycled or disposed of in an environmentally sound manner.
- Do not dispose of your lead-acid battery in a fire. The battery may explode or leak.
- Do not dispose of a lead-acid battery in your regular, household trash. The incineration, land filling or mixing of sealed lead-acid batteries with household trash is prohibited by law.

Our products are suitable for ASTM F963; GB6675; EN71 and EN62115 standard.