

BMW HP4 RACE

BATTERY POWERED TRIKE

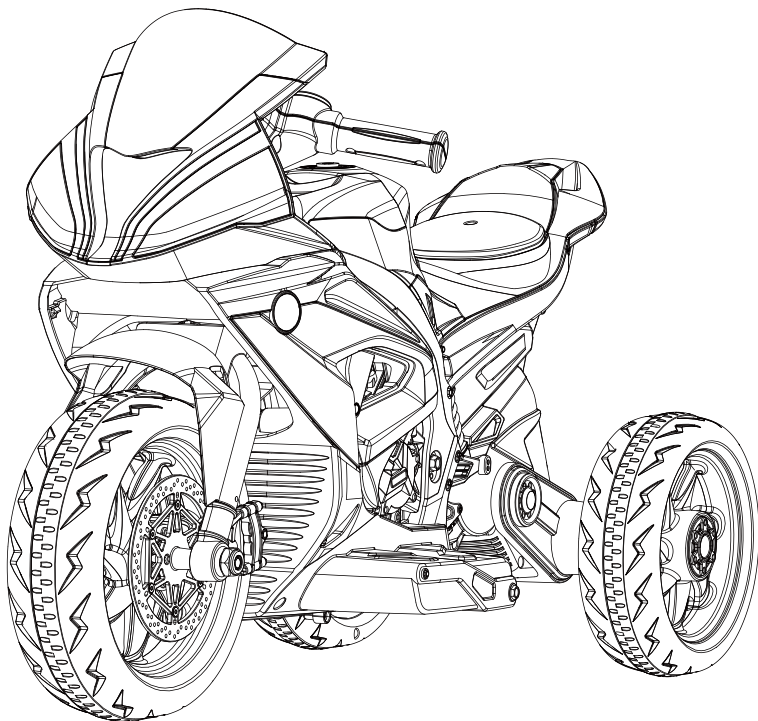

Owner's Manual with Assembly Instructions

Styles and colo(u)rs may vary.
Made in China.

The owner's manual contains important safety information as well as assembly, use and maintenance instructions.

The Ride-on Car must be assembled by an adult who has read and understands the instructions in this manual.

Keep the package away from children and dispose of properly before use.

Keep this manual for future reference.

On the purchase of your new BMW Ride-On.

This ride-on will provide your child with many miles of riding of enjoyment. To help assure you and your rider a safe ride we ask you to please read this manual carefully, and keep it for future reference.

Follow the recommendations in this manual, they are designed to improve the safety and operation of your ride-on car and it's rider.

BMW HP4 Children Battery Powered Trike manufactured by Zhejiang Jiajia Ride-On Co., Ltd. (Add: Xincang Industrial Zone, Pinghu City, Zhejiang Province, P.R.China). The BMW logo and the BMW word mark are trademarks of BMW AG and are used under license.

SPECIFICATIONS:

Battery	6V4AH*1	12V4.5AH*1
Charger	6V500mA	12V500mA

Suitable age:	37-96 months
Load Capacity:	Under 30kg
Speed:	1WD 3km/h 2WD 3-5km/h
Size of car:	82.5 x 42 x 54 CM
Power way:	Charging type
Charge time:	8-12 hours

 **WARNING!**

- **CHOKING HAZARD** - Small parts. Not suitable for children under 36 months. The product contains small parts, keep children away when assembling.
- **ADULT ASSEMBLY REQUIRED.**
- Always remove protective material and poly bags and dispose before assembly.
- Protective equipment should be worn. Always wear shoes and sit in the seat when operating the vehicle.
- Only drive on level ground. Never use on the lawn.
- Never leave a child unattended.
- Keep your hands, hair, and clothes away from moving parts.
- The battery is not replaceable.

 **SAFETY**

The following safety hazards may result in serious injury or death:

- Never leave child unattended. Direct adult supervision is required. Always keep child in view when child is in vehicle.
- To reduce the risk of injury, adult supervision is required. Never use in roadways, near motor vehicles, on or near steep inclines or steps, swimming pools or other bodies of water, always wear shoes, and never allow more than 1 rider.
- Never use in unsafe conditions such as snow, rain, loose dirt, mud, sand, or gravel, otherwise may result in an unexpected accident such as tipping over, and could damage the electrical system or battery
- Not to be used in traffic.
- This toy should be used with caution since skill is required to avoid falls or collisions causing injury to the user or third parties.
- This toy is unsuitable for children under 36 months due to its maximum speed; Maximum user weight is 30kg.
- This toy has no brake.



Use the vehicle on generally level ground ONLY!

DO NOT Use the vehicle on Lawn space!

PART NO.	PART NAME	Q'ty (pcs)		REMARKS
		1WD	2WD	
1	Vehicle body	1	1	
2	Left rear wheel	1	1	
3	Right rear wheel	1	1	
4	Ø10 washer	3	2	Placed on the rear axle
5	Ø10 lock nut	2	2	Placed on the rear axle
6	Hubcap	2	2	
7	Front wheel assembly	1	1	
8	Handle bar	1	1	
9	M5x35 machine screw	1	1	Placed on the steering wheel
10	Ø5 nut	1	1	Placed on the steering wheel
11	Faceguard	1	1	
12	Ø4x16 screw	2	2	
13	Rear axle	1	1	
14	Spanner	2	2	
15	Charger	1	1	

Assembly tools required:

Screwdriver (not included)

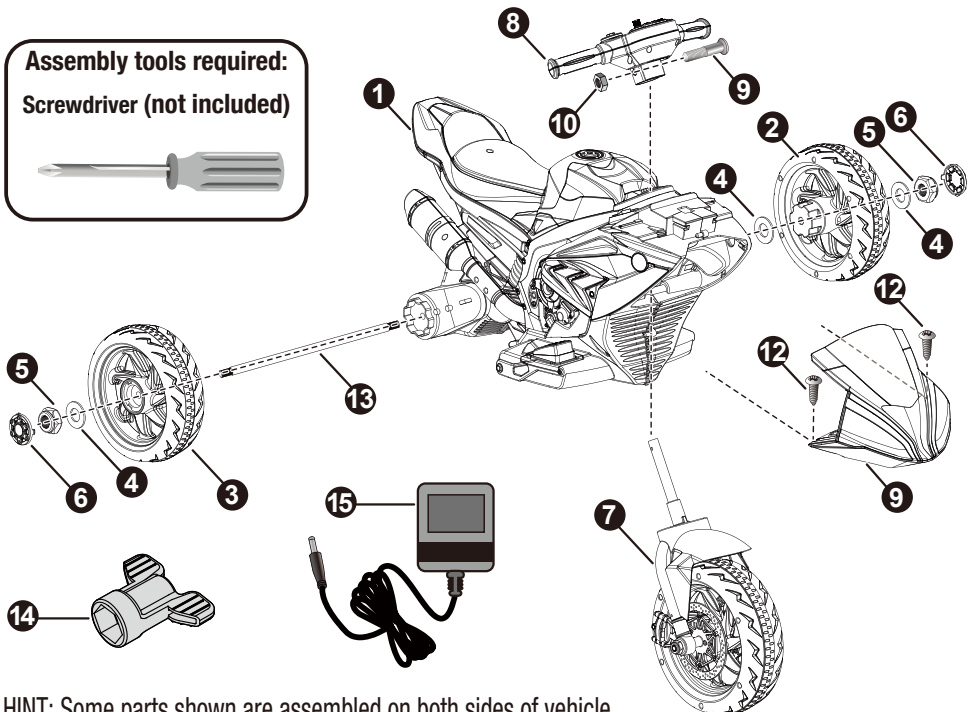

HINT: Some parts shown are assembled on both sides of vehicle

1WD

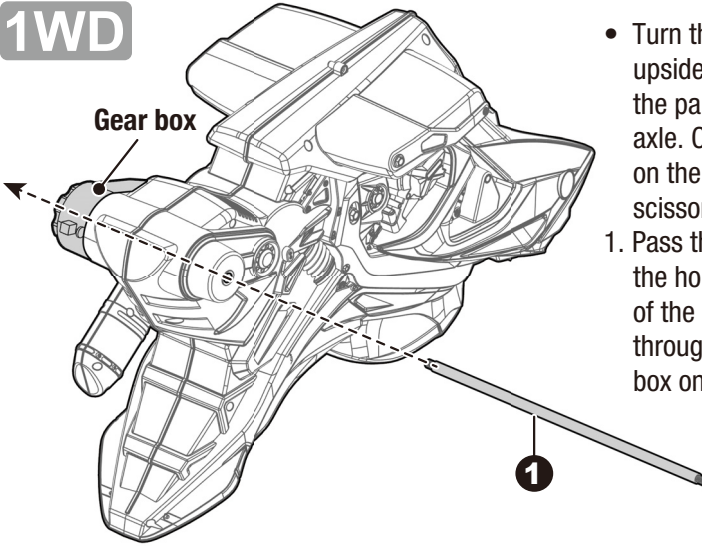

- Turn the vehicle body upside down. Remove all the parts from the rear axle. Cut the rubber band on the gear box with scissors.

1. Pass the rear axle through the hole on the right side of the body, and out through the hole in gear box on the other side.

Rear Bottom View

2WD

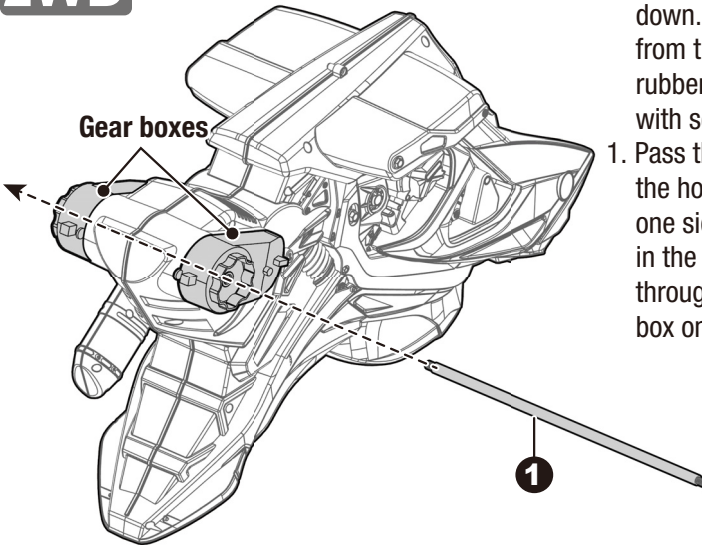

- Turn the vehicle body upside down. Remove all the parts from the rear axle. Cut the rubber band on the gear box with scissors.

1. Pass the rear axle through the hole in the gear box on one side of the body, the hole in the vehicle body, and out through the hole in the gear box on the other side.

Rear Bottom View

HINT: If your product is a two-wheel driving type, please refer to the next page.

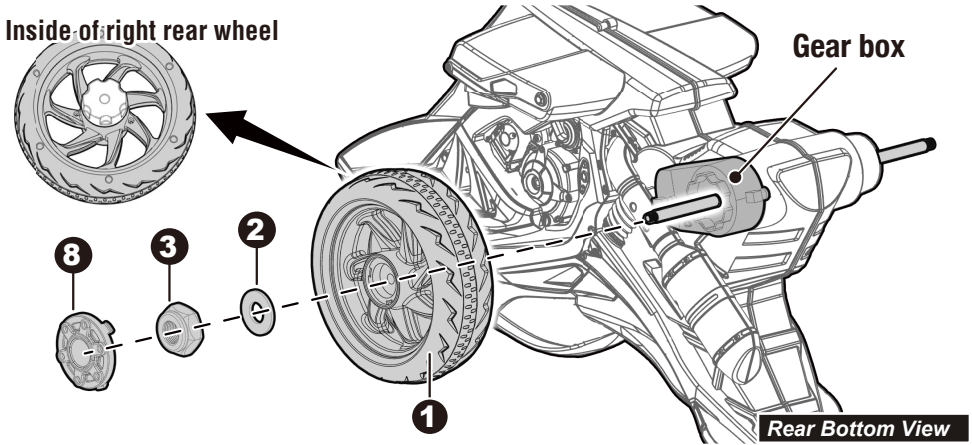

1. Slide the right rear wheel onto the rear axle from the left side of the vehicle body, and make it match up with the motor on the vehicle body.
2. Slide a $\varnothing 10$ washer onto the rear axle.
3. Tighten a lock nut to the end of the rear axle with a spanner.

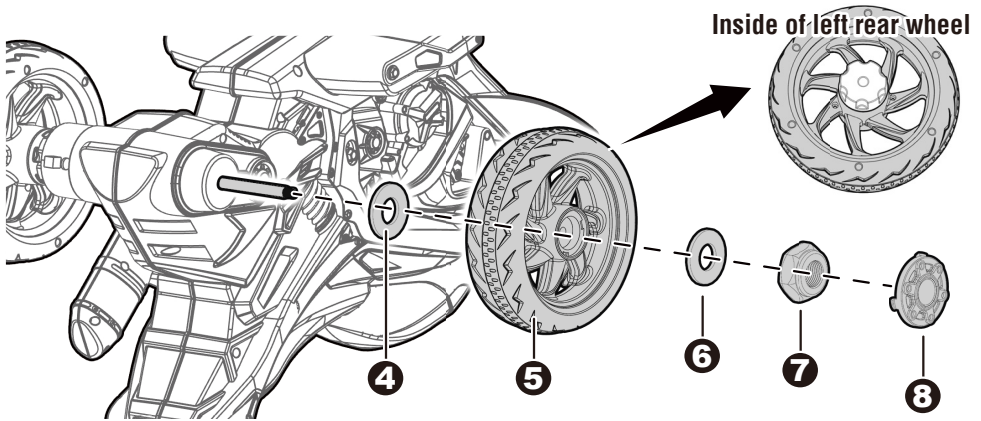

4. Slide the $\varnothing 10$ washer on the other side of the rear axle.
5. Slide the left rear wheel onto the rear axle.
6. Slide another $\varnothing 10$ washer onto the rear axle.
7. Tighten a lock nut to the end of the rear axle with a spanner. **TIP:** An extra spanner has been provided to hold the Lock Nut on the other side of the rear axle while tightening the Lock Nut on the other side.
8. Fit the hubcaps to the both rear wheels.

HINT: If your product is a one-wheel driving type, please refer to the previous page.

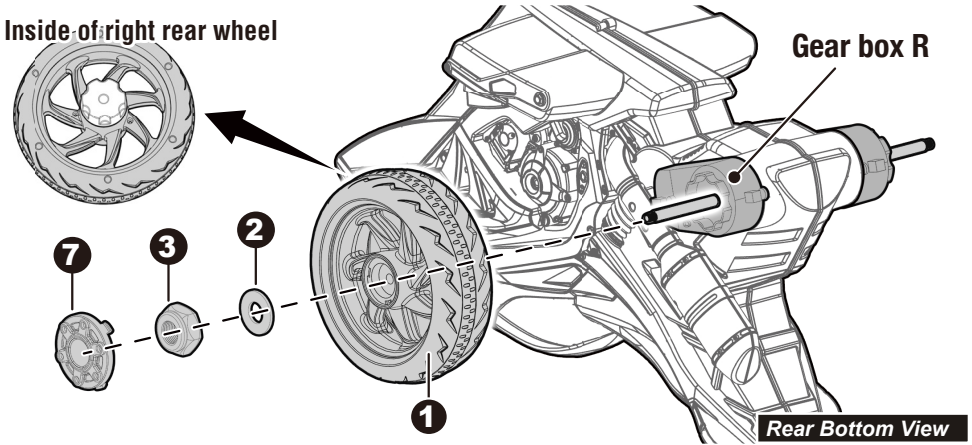

1. Slide the right rear wheel onto the rear axle from the left side of the vehicle body, and make it match up with the motor on the vehicle body.
2. Slide a $\varnothing 10$ washer onto the rear axle.
3. Tighten a lock nut to the end of the rear axle with a spanner.

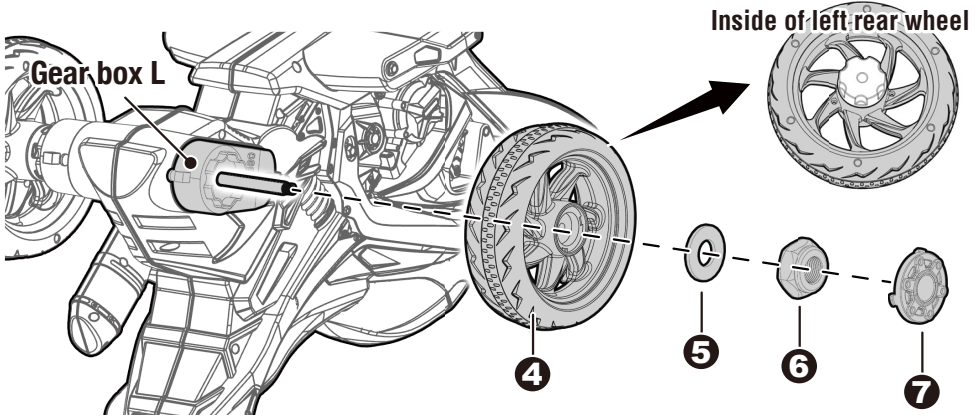

- 4-6. Repeat the above steps to assemble the other rear wheel. **TIP:** An extra spanner has been provided to hold the Lock Nut on the other side of the rear axle while tightening the Lock Nut on the other side.
7. Fit the hubcaps to the both rear wheels.

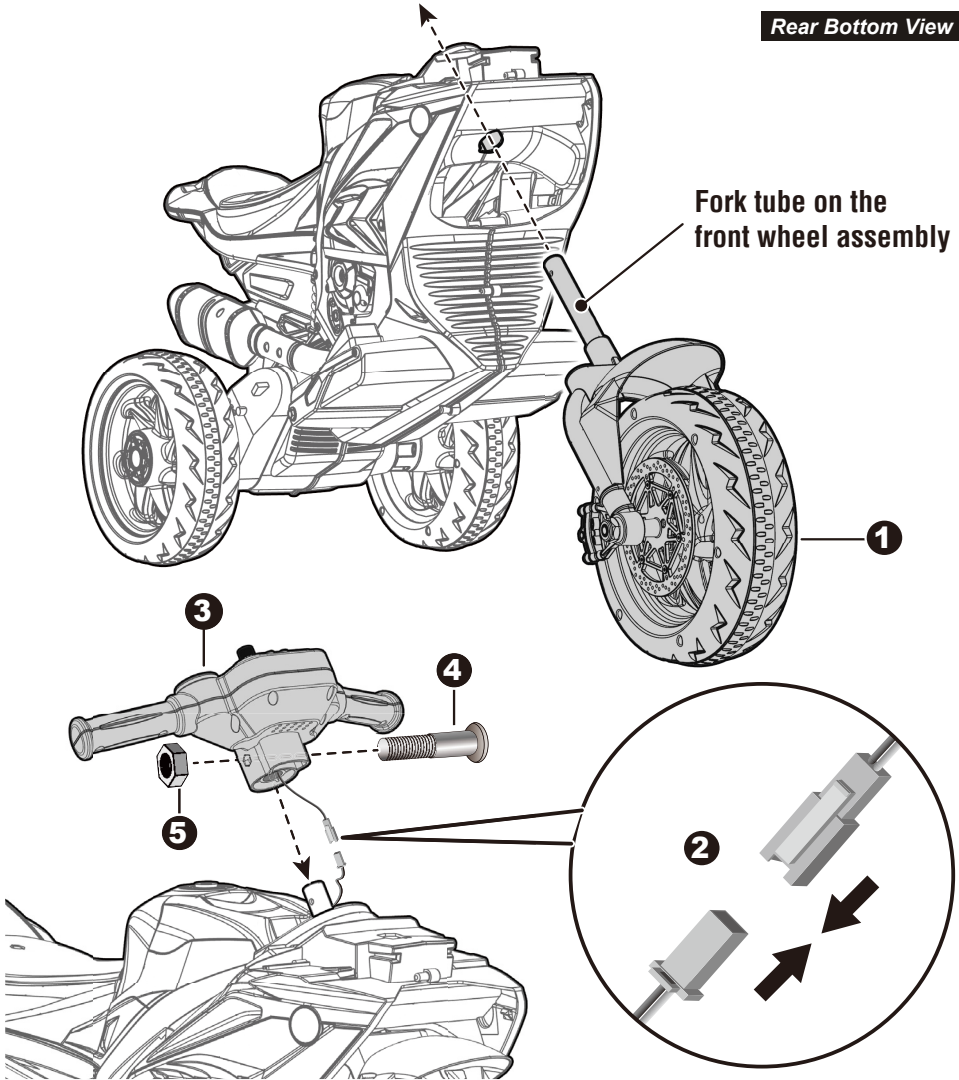

Turn the vehicle body upright.

1. Raise up the vehicle body, insert the fork tube on the front wheel assembly passes through the hole in the bottom of the vehicle body.
2. Plug the connector on the handlebar with the connector on the vehicle body, and then hide the connectors into the hole of the vehicle body.
3. Fit the handlebar into the fork tube on the front wheel assembly.
4. Align the holes on each side of the handle bar with the holes at the front fork.
5. Fasten a $\varnothing 5$ nut on the opposite end of the M5x35 machine screw to secure the handle bar to the front fork.

Attach the Faceguard | 7

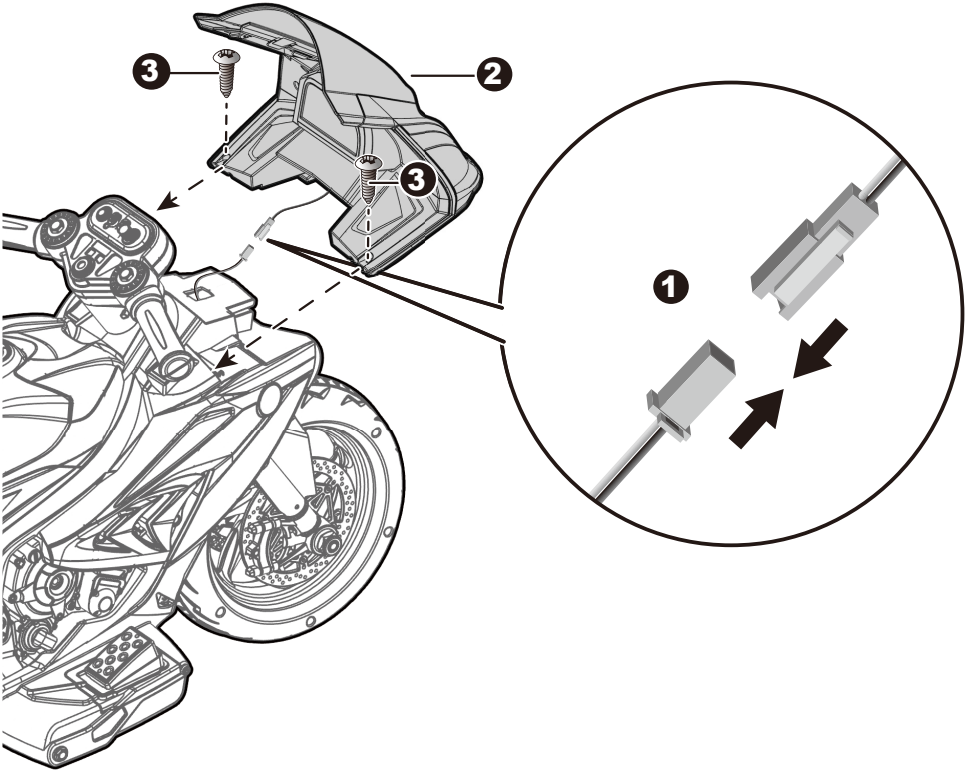

1. Plug the connector on the faceguard in the connector on the vehicle body. And hide connectors into the hole in the vehicle body.
2. Fit the faceguard to the vehicle body.
3. Use a screwdriver to tighten two $\varnothing 4 \times 16$ screws to secure it.

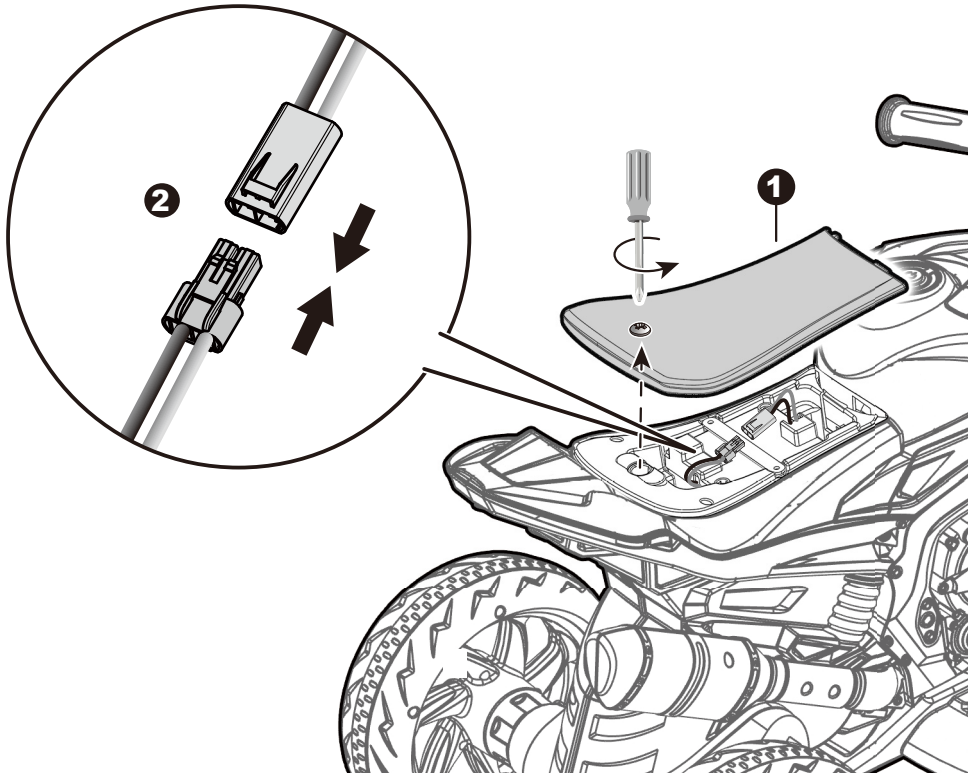

1. Loosen the screws on the top of the seat with a screwdriver and remove the seat.
2. Plug the connector on the vehicle body into the connector from the battery.

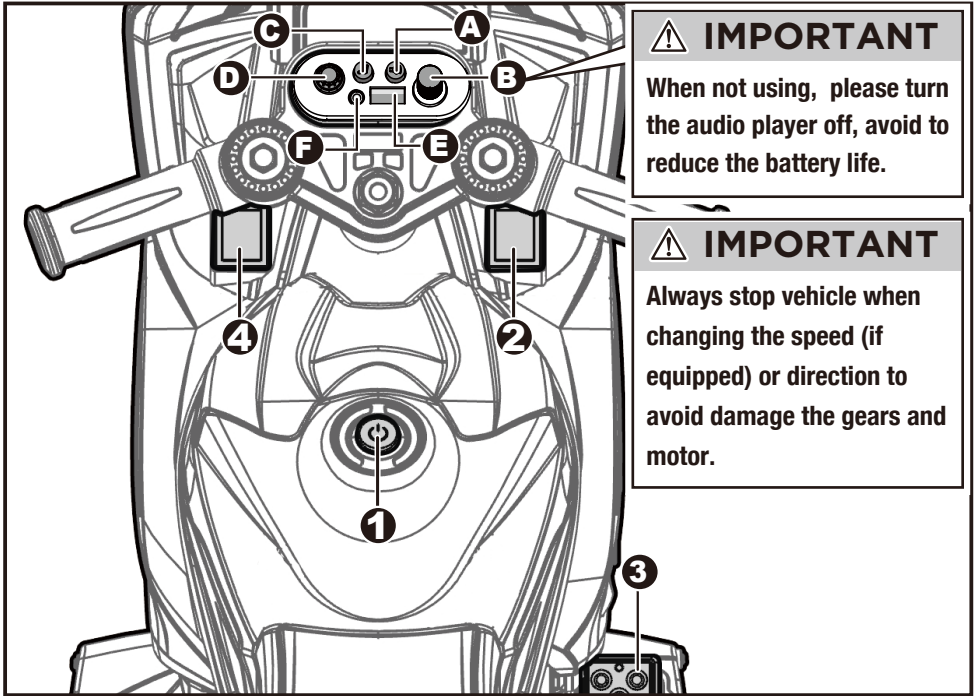

1. **Power button:** Turns the vehicle on and off.
2. **Forward/reverse switch:** Changes the direction that vehicle moves from forward to reverse.
 - To move the vehicle forward, shift the lever to top position.
 - To move the vehicle backward, shift the lever to down position.
3. **Foot pedal:** Applies power (speed) to the vehicle.
 - To move the car, press the pedal down.
 - To brake or slow down, release pressure from the pedal.
4. **High/Low speed switch (if equipped, Only for 2WD type):** Operates the product to move forward in high speed and low speed.
- A. **Sound buttons:** Press for sounds playing.
- B. **Volume knob:** Turn the audio player on and off, +/- the volume.
- C. **Music / Wake button:** Press for music playing.

TIP: This player has an power-saving function. If it is idle for three minutes when it is turned on, the player will enter sleep mode. Press this button to wake up the player from sleep mode.
- D. **Study / Nursery rhyme button.**
- E. **Device 1 input.**
- F. **Device 2 input.**

⚠ WARNING!

- **ONLY an adult is allowed charge and recharge the battery!**
- **This product with Charging Protection: when charging, all functions will be cut off.**

- The POWER SWITCH must be turned in OFF position when charging.
- Before the first use, you should charge the battery for 4-6 hours. Do not recharge the battery for more than 10 hours to avoid overheating the charger.
- When the vehicle begins to run slowly, recharge the battery.
- After each use or once a month minimum recharge time as 8 to 12 hours, less than 20 hours at most.
- Use the only rechargeable battery and charger specified by the manufacturer. NEVER substitute the battery or the charger with another brand. Using another battery or charger may cause a fire or explosion.
- Do not use the battery or charger for any other product.

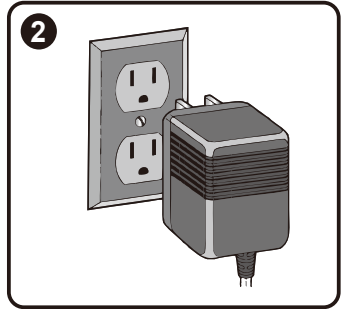
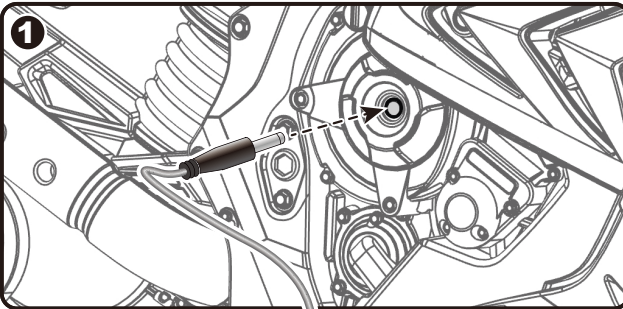

1. Plug the charger port into the input socket (the socket is above the foot pedal).
2. Plug the charger plug into a wall outlet. The battery will begin charging.

Battery Disposal

The battery will eventually lose the ability to hold a charge. Depending on the amount of use, and varying conditions, the battery should operate for one to three years.

Important! Recycle the dead battery responsibly. The battery contains lead acid (electrolyte) and must be disposed of properly and legally. It is illegal in most areas to incinerate lead acid batteries or dispose of them in landfills. Take it to a federal or state-approved lead acid battery recycler, such as local automotive battery retailer.

Do not throw the battery away with your regular household waste!

- It is parents' responsibility to check main parts of the toy before using, Must regularly examine for potential hazard, such as the battery, charge, cable or cord, plug, screws are fastening enclosure of other parts and that in the event of such damage, the toy must not be used until that damage had been properly removed.
- Park the vehicle indoors or cover it with a tarp to protect it from wet weather.
- Recharge the battery after each use. Only an adult can handle the battery. Recharge the battery at least once a month when the vehicle raider is not being used.
- Do not wash the vehicle with a hose. Do not wash the vehicle with soap and water. Do not drive the vehicle in rainy or snowy weather. Water will damage the motor, electric system and battery.
- Clean the vehicle with a soft, dry cloth. To restore shine to plastic parts, use a non-wax furniture polish. Do not use car wax. Do not use abrasive cleaners.
- When not using, all the electrical source should be turn off. Turn off the power switch and disconnect the battery connection.

Fuse

The battery features a thermal fuse with a reset fuse that will automatically trip and cut all power to the vehicle if the motor, electric system or battery is overloaded. The fuse will reset and power will be restored after the unit is turned OFF for 20 seconds and then turned ON again. If the thermal fuse trips repeatedly during normal use, the vehicle may need repair. Contact your distributor please.

To avoid losing power, follow these guidelines:

- Do not overload the vehicle.
- Do not tow anything behind the vehicle.
- Do not drive up steep slopes.
- Do not drive into fixed objects, which may cause the wheels to spin, causing the motor to overheat.
- Do not drive in very hot weather, components may overheat.
- Do not allow water or other liquids to come in contact with the battery or other electric components.
- Do not tamper with the electric system. Doing so may create a short, causing the fuse to trip.

Problem	Possible Cause	Solution
Vehicle does not run	Battery low on power	Recharge battery.
	Thermal fuse has tripped	Reset fuse, see <Fuse>
	Battery connector or wires are loose	Check that the battery connectors are firmly plugged into each other. If wires are loose around the motor contact your distributor please.
	Battery is dead	Replace battery, contact your distributor please.
	Electrical system is damaged	Contact your distributor please.
	Motor is damaged	Contact your distributor please.
Vehicle does not run very long	Battery is under charged	Check that the battery connectors are firmly plugged into each other when recharging
	Battery is old	Replace battery, contact your distributor please.
Vehicle runs sluggishly	Battery low on power	Recharge battery, contact your distributor please.
	Battery is old	Replace battery, contact your distributor please.
	Vehicle is overload	Reduce weight on vehicle.
	Vehicle is being used in harsh conditions	Avoid using vehicle in harsh conditions, see <Safety>.
Vehicle needs a push to go forward	Poor contact of wires or connectors	Check that the battery connectors are firmly plugged into each other. If wires are loose around the motor, contact your distributor please.
	“Dead Spot” on motor	A dead spot means the electric power is not being delivered to the terminal connection and the vehicle needs repair. Contact your distributor please.
Difficult shifting from forward to reverse or vice-versa	Attempting to shift while the vehicle is motion	Completely stop the vehicle and shift, see <Use Your Ride-On>
Loud grinding or clicking noises coming from motor or gear box	Motor or gears are damaged	Contact your distributor please.
Battery will not recharge	Battery connector or adapter connector is loose	Check that the battery connectors are firmly plugged into each other.
	Charger not plugged in	Check that the battery charger is plugged into a working wall outlet.
	Charger is not working	Contact your distributor please.
Charger feels warm when recharging	This is normal and not a cause for concern	

Completely read through this manual and the troubleshooting guide table before calling. If you still need help resolving the problem **Contact your distributor please.**

**Our products are suitable for
ASTM F963; GB6675; EN71 and EN62115 standard.**